



# JCM Industries, Inc.

**Fittings & Fabrications  
for Repair - Connection - Branching  
All Types and Sizes of Pipe**

JCM Industries, Inc.  
P.O. Box 1220 - Nash, TX 75569-1220  
Office: 903-832-2581, Fax: 903-838-6260  
www.jcmindustries.com

Call Toll Free: 800-527-8482  
Fax Toll Free: 800-874-9524  
Email: sales@jcmindustries.com

## JCM 6136 Heavy Duty All 316 Stainless Repair Clamp Coupling

The JCM 6136 Heavy Duty Stainless Steel Repair Clamp incorporates the corrosion resistance of stainless steel, the full circumferential gasketing of a Universal Clamp Coupling and the triangular bolting configuration of the 6432 All 316 Stainless Steel Tapping Sleeve to provide a repair clamp coupling with high working pressure capabilities.

**All Stainless Steel Construction** - provides superior corrosion resistance in harsh or acidic environments.

**Heavy Duty Stainless Material** - the JCM 6136 has a minimum standard material of 14 gauge certifiable prime material. This strong, yet flexible stainless shell conforms to uneven or unusual pipe surfaces and provides complete compression of the gasket on the pipe wall.

**Tapping Sleeve Bolting System** - with a triangular lug design, allows for pass-through, replaceable bolts. This lug configuration eliminates alignment problems and allows tightening from either side of the pipe.

**Full Circumferential Gasket** - provides a water tight seal on the full circumference of the pipe. The gridded 1/4" thick gasket is of a durometer hardness that allows the rubber to conform to and fill the pits and voids of uneven pipe surfaces.

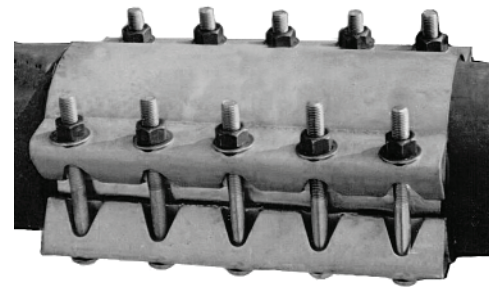

Typical Application Repair pipe in service -  
Temporary or permanent

- Breaks
- Cracks
- Splits
- Holes
- Corroded Areas
- Gouges

Suitable for Cast Iron, Ductile Iron, Asbestos  
Cement, Steel, HDPE and others

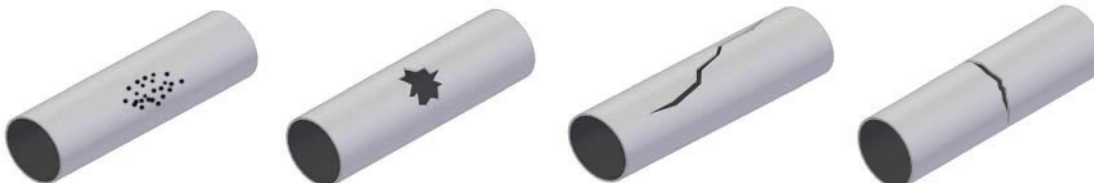

**JCM 6136 Heavy Duty Stainless Steel Repair Clamp** - shall have a minimum material standard of 14 gauge certifiable prime 316 stainless steel construction. Clamps shall have a triangular lug design with bolts on 3" centers. Bolts shall be the passthrough, replaceable type to avoid alignment problems and allow tightening from either side of the pipe. Bolts shall not be integrally welded to the sleeve. Bolts shall be minimum 5/8" 316 stainless steel track head type furnished with permanently lubricated heavy hex nuts and stainless steel washers. The full circumferential gasket shall be molded of synthetic rubber compounded for use with water salt solutions, mild acids, bases and sewage. The gasket shall have a gridded surface, be a full 1/4" thick with 316 stainless steel bridge plates molded flush into the gasket. Clamps shall be fully passivated to insure corrosion resistance.

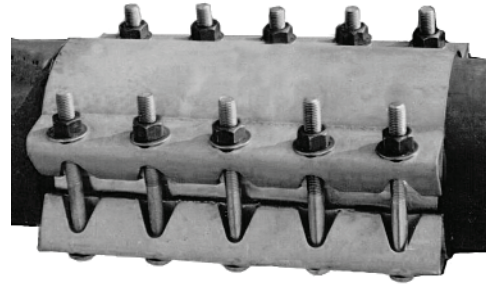

**HOW TO ORDER - For price and engineering, furnish the following information**

- |                       |                                |
|-----------------------|--------------------------------|
| Type of Pipe          | Type of Damage                 |
| Pipe Outside Diameter | Dimension of Damaged Area      |
| Line Content          | Space Limitations              |
| Line Working Pressure | Optional Material Requirements |

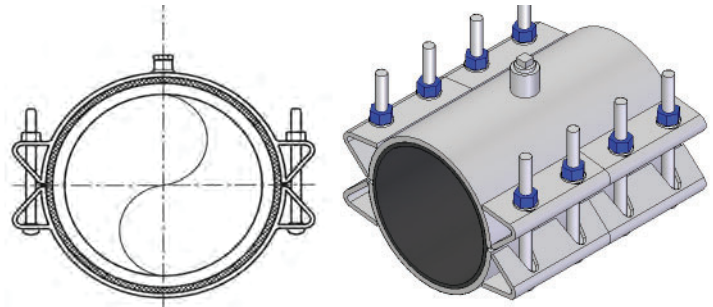
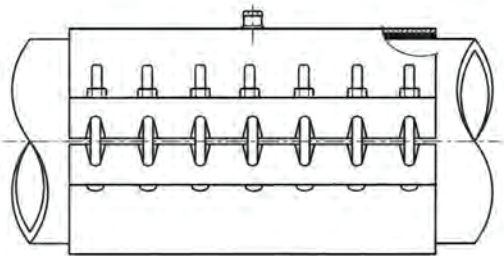

The JCM 6136 Heavy Duty Stainless Repair Clamp is available for all types and sizes of pipe. Options for this fitting includes: with or without threaded outlet; SBR, EPDM or Buna-N Gaskets. Call the JCM Inside Sales Team for product recommendations.



JCM Industries, Inc.  
P.O. Box 1220  
Nash, TX 75569-1220  
[www.jcmindustries.com](http://www.jcmindustries.com)