

# JCM INDUSTRIES

P. O. Box 1220, Nash, TX 75569-1220

Phone 800-527-8482 or 903-832-2581

Fax 800-874-9524 or 903-838-6260

[www.jcmindustries.com](http://www.jcmindustries.com)

## Typical Specification

### JCM 174 Tapped Multi-Band Clamps (sizes 4" through 8")

All full circumferential multi-band repair clamps 4" – 8" shall have a minimum material standard of certifiable prime 304 Stainless Steel band; heavy duty, low profile Ductile Iron Lugs per ASTM A536 with mutually supporting sliding fingers; 5/8" corrosion resistant alloy bolts, per ASTM A242/ANSI 21.1/AWWA C-111, and a 1/4" thick Styrene-Butadiene Rubber (SBR) gridded gasket with tapered lap joint ends and a 304 stainless steel bridge plate molded flush into the gasket. Gaskets shall be 1/4" thick. Open ear lug shall be removeable from the band to facilitate sliding band under pipe or installing in confined spaces. Clamp shall be similar to JCM 174 Tapped Extended Universal Clamp Coupling or approved equal. Optional features available; see material specification.

### JCM 174 Tapped Multi-Band Clamps (sizes 10" and larger)

All full circumferential multi-band repair clamps 10" and larger shall have a minimum material of 17 gauge certifiable prime 304 Stainless Steel band; heavy duty Ductile Iron Lugs per ASTM A536 with mutually supporting sliding fingers; 3/4" corrosion resistant alloy bolts, per ASTM A242/ANSI 21.11/AWWA C-111, and a 1/4" thick Styrene-Butadiene Rubber (SBR) gridded gasket with tapered stainless steel bridge plate molded flush into the gasket. Open ear lug shall be removeable from the band to facilitate sliding band under pipe or installing in confined spaces. Clamp shall be similar to JCM 174 Tapped Extended Range Universal Clamp Coupling or approved equal. Optional features available; see material specification.

JCM 100 Series Universal Clamp Couplings are ANSI/NSF Standard 61, Annex G and ANSI/NSF Standard 372 Certified.

JCM 100 Series Universal Clamp Couplings meet or exceed ANSI/AWWA C230 Standard for Stainless – Steel Full-Encirclement Repair and Service Connection Clamps as applicable.



JCM 174 Tapped Multi Band Universal Clamp  
Coupling  
Image reflects 12" width

*This typical specification, provided by JCM Industries, is a proposed guideline for use by specifying agencies to ensure significant design and material features of this product are included within the agencies' individual specifications.*

# JCM INDUSTRIES

P. O. Box 1220, Nash, TX 75569-1220

Phone 800-527-8482 or 903-832-2581

Fax 800-874-9524 or 903-838-6260

[www.jcmindustries.com](http://www.jcmindustries.com)

## Material Specification

### JCM Universal Clamp Couplings – Models 174 Tapped

- Band:** 18-8 Type 304 Certifiable Prime Stainless Steel
- Lugs:** Ductile Iron ASTM A-536, 60-40-18
- Bolts:** Corrosion resistant low alloy per ASTM A242, ANSI A21.11, AWWA C-111. National coarse rolled thread and heavy hex nut. Optional Stainless Steel 18-8 Type 304 or 316 available. Optional Epoxy Coated low alloy bolts/nuts available.
- Gaskets:** Virgin Styrene-Butadiene Rubber (SBR) - Compounded for use with water, salt solutions, mild acids and bases. Per ASTM D-2000 M4AA 607. Standard temperature range from -40° to 150°F (-40° to 65° C) constant, maximum intermittent 180° F (82° C). For applications on high temperatures or chemical pipelines, contact JCM Industries Technical Services.
- Outlet:** 304 stainless steel
- Coating:** Corrosion resistant shop coat paint primer.
- Pressure Rating:** Rated for working pressure of 150 PSI (i.e. pinholes, cracks less than 1/16", etc.). Pressure holding capabilities vary according to application. For higher pressure ratings, contact JCM Industries Technical Services.

JCM 100 Series Universal Clamp Couplings are ANSI/NSF Standard 61, Annex G and ANSI/NSF Standard 372 Certified.

JCM 100 Series Universal Clamp Couplings meet or exceed ANSI/AWWA C230 Standard for Stainless – Steel Full-Encirclement Repair and Service Connection Clamps as applicable.



# JCM INDUSTRIES

P. O. Box 1220, Nash, TX 75569-1220  
 Phone 800-527-8482 or 903-832-2581  
 Fax 800-874-9524 or 903-838-6260

[www.jcmindustries.com](http://www.jcmindustries.com)

## JCM 174 Tapped Extended Range Double Band Universal Clamp Coupling Design Specifications Sizes 4" – 20"

Clamp Width (Inches)	Number of Bolts
6	4
7	4
12	8
15	8
18	12
24	16
30	20

Clamp Size (Inches)	Stainless Band Gauge
4 - 8	20
10 and larger	17 minimum

Clamp Size (Inches)	Gasket Thickness
4 and larger	1/4"

Clamp Size (Inches)	Bolt Size
4 – 8	5/8"
10 and larger	3/4"

Design specifications for Multi-Band Clamps 24" and larger are available upon request.

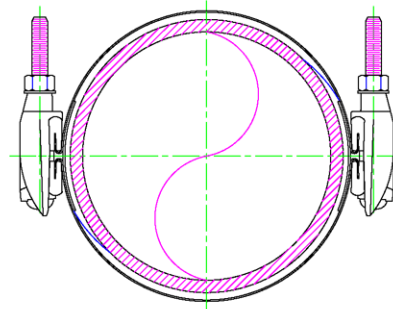
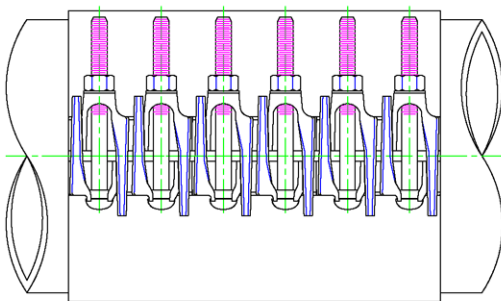

JCM 174 Tapped Multi Band Universal Clamp  
 Coupling  
 Image reflects 18" width



Effective 11.11.20