

JCM INDUSTRIES

P. O. Box 1220, Nash, TX 75569-1220

Phone 800-527-8482 or 903-832-2581

Fax 800-874-9524 or 903-838-6260

www.jcmindustries.com

Typical Specification

JCM 103 Tapped Universal Clamp Couplings

All full circumferential single band repair clamps 1-1/2" and larger shall have a minimum material standard of certifiable prime 304 Stainless Steel band; heavy duty, low profile Ductile Iron Lugs per ASTM A536 with mutually supporting sliding fingers; 5/8" corrosion resistant alloy bolts, per ASTM A242 / ANSI 21.11 / AWWA C-111, and a Styrene-Butadiene Rubber (SBR) gridded gasket with tapered lap joint ends and a 304 stainless steel bridge plate molded flush into the gasket. Gaskets in sizes 3" and larger shall be 1/4" thick. To provide extra tightening capability, the band shall be permanently attached to the lugs by crimping the lug and locking it in place with a minimum of three stainless welds per lug. Clamp shall be similar to JCM 103 Universal Clamp Coupling with Tapped Outlet or approved equal. Optional features available; see material specification.

JCM 103 Tapped Universal Clamp Couplings (sizes 10" and larger)

All full circumferential single band repair clamps 10" and larger shall have a minimum material of 17 gauge certifiable prime 304 Stainless Steel band; heavy duty Ductile Iron Lugs per ASTM A536 with mutually supporting sliding fingers; 3/4" corrosion resistant alloy bolts, per ASTM A242 / ANSI 21.11 / AWWA C-111, and a 1/4" thick Styrene-Butadiene Rubber (SBR) gridded gasket with tapered stainless steel bridge plate molded flush into the gasket. To provide extra tightening capability, the band shall be permanently attached to the lugs. The attachment shall withstand a minimum of 100 ft. lbs. of torque per bolt. Clamp shall be similar to JCM 103 Universal Clamp Coupling with Tapped Outlet or approved equal. Optional features available; see material specification.

JCM 100 Series Universal Clamp Couplings are ANSI/NSF Standard 61, Annex G and ANSI/NSF Standard 372 Certified.

JCM 100 Series Universal Clamp Couplings meet or exceed ANSI/AWWA C230 Standard for Stainless –Steel Full-Encirclement Repair and Service Connection Clamps as applicable.



Image reflects 6" width

This typical specification, provided by JCM Industries, is a proposed guideline for use by specifying agencies to ensure significant design and material features of this product are included within the agencies' individual specifications.

JCM INDUSTRIES

P. O. Box 1220, Nash, TX 75569-1220

Phone 800-527-8482 or 903-832-2581

Fax 800-874-9524 or 903-838-6260

www.jcmindustries.com

Material Specification

JCM 103 Tapped Universal Clamp Couplings

Band: 18-8 Type 304 Certifiable Prime Stainless Steel

Lugs: Ductile Iron ASTM A-536, 60-40-18

Bolts: Corrosion resistant low alloy per ASTM A242, ANSI A21.11, AWWA C-111. National coarse rolled thread and heavy hex nut.
Optional Stainless Steel 18-8 Type 304 or 316 available.
Optional Epoxy Coated low alloy bolts/nuts available.

Gasket: Virgin Styrene-Butadiene Rubber (SBR) - Compounded for use with water, salt solutions, mild acids and bases. Per ASTM D-2000 M4AA 607. Standard temperature range from -40° to 150°F (-40° to 65° C) constant, maximum intermittent 180° F (82 ° C). For applications on high temperatures or chemical pipelines, contact JCM Industries Technical Services.

Coating: Corrosion resistant shop coat paint primer.

Tapped Outlet: 18-8 Type 304 Stainless Steel

JCM 100 Series Universal Clamp Couplings are ANSI/NSF Standard 61, Annex G and ANSI/NSF Standard 372 Certified.

JCM 100 Series Universal Clamp Couplings meet or exceed ANSI/AWWA C230 Standard for Stainless –Steel Full-Encirclement Repair and Service Connection Clamps as applicable.

For ranges and widths, see JCM Industries General Product Directory Catalog.

Information based on data available at the date printed below and subject to change without notice. Contact JCM Industries for amendments or changes.



Effective 11.11.20

JCM INDUSTRIES

P. O. Box 1220, Nash, TX 75569-1220

Phone 800-527-8482 or 903-832-2581

Fax 800-874-9524 or 903-838-6260

www.jcmindustries.com

JCM 103 Tapped Universal Clamp Coupling Design Specifications

Clamp Width (Inches)	Number of Bolts
6	2
7	2
12	4
15	4
18	6
24	8
30	10

Clamp Size (Inches)	Stainless Band Gauge
1-1/2 – 4.50	24
4.80 – 9.40	20
10 – 12	17

Clamp Size (Inches)	Gasket Thickness
1-1/2 – 2	3/16"
3 and larger	1/4"

Clamp Size (Inches)	Bolt Size
1-1/2 – 8	5/8"
10 – 12	3/4"

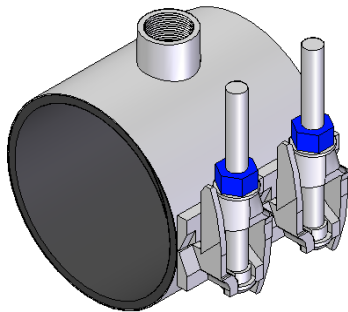

Image reflects 7" width



Effective 11.11.20